

INSULATED PASS-THRU STAINLESS STEEL HOT CABINET MODEL H-138-PS-1834C

FEATURES AND BENEFITS:

- Fully insulated hot cabinet keeps prepared foods at serving temperatures. Ideal for fried foods.
- Pass-thru design allows for access from preparation and serving areas.
- Powerful, yet efficient, 2000 Watt heating system maintains the right temperature to properly hold products. Heats up to 200°F (93°C).
- Control panel has easy-to-read thermometer; self-contained power top allows interior of cabinet to be hosed-out during cleaning.
- Internal frame in body maintains structural rigidity.
- Stainless steel construction throughout for ease of cleaning. One piece extended base protects cabinet body.
- Smooth interior covered corners prevent food particles/grease buildup.
- Safety-conscious anti-microbial latches protect against spreading germs.
- Insulated Dutch doors on front and back of cabinet prevent temperature loss. Field reversible for flexibility.
- Standard with right hand hinging; left hand hinging available upon request.
- High temperature ceramic magnetic latches for "easy open"; twist-lock catch secures door during transport. Latches and hinges mounted inboard.
- Extruded aluminum channels securely hold 18" x 26" pans on 1-1/2" centers without tipping.
- Heavy duty 5" swivel casters, two with brakes. Provides mobility when fully loaded.



H-138-PS-1834C



ACCESSORIES and OPTIONS (Available at extra cost):

- Tempered Glass Door Windows
- Lock Hasp
- Corner Bumpers
- Perimeter Bumper
- Floor Lock (for use with 5" casters)
- Various Caster Options
- Food Safe Digital Thermometer
- 208 or 240 Volt Service

See page B-20 for accessory details.

H-138-PS-1834C

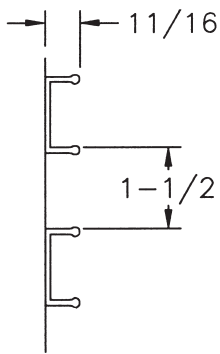

DETAIL OF PAN SLIDE

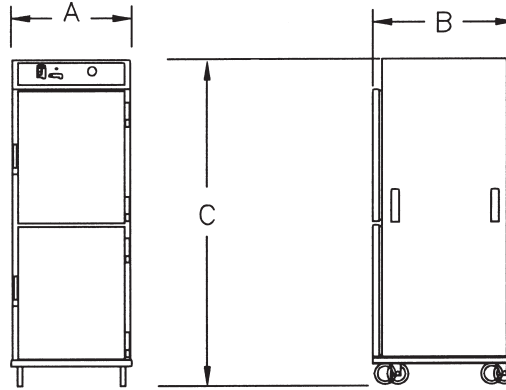
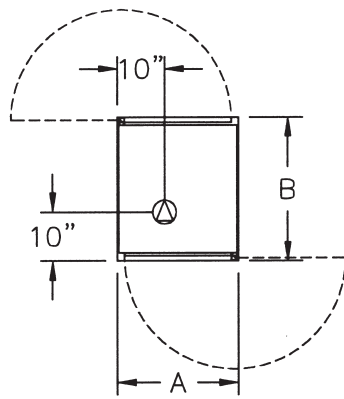

CRES COR MODEL NO.	PAN			DIM "A"	DIM "B"	DIM "C"	INSIDE DIMENSIONS			WEIGHT ACT.	
	CAP	SIZE		WIDTH	DEPTH	HEIGHT	WIDTH	DEPTH	HEIGHT		
H-138-PS-1834C	32	18 X 26	IN	28-3/4	35	73	18-1/16	27-1/2	58	LBS	302
		460 X 660	MM	730	890	1855	460	700	1475	KG	137

When ordering bumpers, add 2" to overall dimensions.

ALL CONSTRUCTION IS RIVETED, WELDED AND FINISHED.

CABINET:

- Body: 22 ga. stainless steel.
- Reinforcement: Internal framework of 18 ga. stainless steel.
- Insulation: Fiberglass, thermal conductivity (K factor) is .23 at 75°F. 1-1/2" in doors, top, base; 2" in sidewalls.
- Air tunnels (2): 22 ga. stainless steel; lift-out type, mounted on side walls.
- Push/pull handles (4): 5" vertical; recessed.
- Interior coved corners.

BASE:

- One piece construction, .125 aluminum.
- Casters: 5" dia., swivel, modulus tires, 1-1/4 wide, load cap. 250 lbs. each, temp. range -45°/+180°F. Delrin bearings. Front casters equipped with brakes.

DUTCH DOORS:

- Field reversible.
- Formed 22 ga. stainless steel.
- Latches: Chrome plated steel, high temperature ceramic magnetic type, mounted inboard.
- Transport latches.
- Hinges: Heavy duty chrome plated steel.
- Gaskets: Perimeter type, silicone.
- Pan stops: Embossed.

PAN SLIDES:

- Channels: Extruded aluminum, 11/16 x 1-1/2 x .100, riveted on 1-1/2" centers.

HOT UNIT COMPONENTS:

- Top mounted; removable with tools.
- Thermostat: Mechanical, room ambient to 200°F (93°C).
- Switch: ON-OFF rocker type.
- Power light
- Power cord: Permanent, 10 ft., 12/3 ga.
- Heaters (2): 1000 Watts each.
- Blower motors (2).
- Vent fan.
- Thermometer: Analog.

POWER REQUIREMENTS:

- 2000 Watts, 120 Volts, 60 Hz., single phase, 16 Amps., 20 Amp. service.

SHORT FORM SPECIFICATIONS

Cres Cor Insulated Pass-Thru Hot Cabinet Model H-138-PS-1834C. 2000 Watts, 125 Volts. Cabinet 22 ga. stainless steel; stainless steel internal frame. Dutch doors front and back, 22 ga. stainless steel. Fiberglass insulation in sides 2"; doors, top, base 1-1/2". Interior coved corners. Hose out cleaning capability. 2000 Watt, 120 Volt power unit. Aluminum channels for (32) 18" x 26" pans, riveted on 1-1/2" centers. One piece insulated base, .125 aluminum. 5" swivel modulus casters, Delrin bearings. Load capacity 250 lbs. each. 2 year parts warranty. Provide the following accessories: _____ . NSF, CSA-US, CSA-C, ENERGY STAR Qualified.



5925 Heisley Road • Mentor, OH 44060-1833
 Phone: 877/CRESCOR • Fax: 440/350-7267
 www.crescor.com

© Crescent Metal Products, Inc. 2010 All rights reserved.

In line with its policy to continually improve its products, CRES COR reserves the right to change materials and specifications without notice.

Litho in U.S.A.